



ZG13TE

ZERO-GAP HYDRAULIC FLANGE SPREADER



SPREADING FORCE = 13 T (130 kN) per tool
It is recommended that tools are used in pairs giving
2 x 13 = 26 T (260 kN)
SPREADING DISTANCE = 0-115mm (0-4.53")

TOOL WEIGHT = 21.5 kg (47.3 lbs)

KIT COMPONENTS

- 1 x ZG13TE Tool c/w Hydraulic Cylinder
- 1 x 10,000 psi (700 bar) HP350S Sealed Hand Pump with Gauge
- 1 x 10,000 psi (700 bar) Hydraulic Hose, 2 m (78.75")
- 1 x 150mm (5.91") Vernier Calliper
- 1 x Tommy Bar
- 1 x 30 mm (1 1/8") Drive Socket
- 1 x Safety Block
- 2 x M39 (1 1/2") Collets
- 2 x M42 (1 5/8") Collets
- 2 x M45 (1 3/4") Collets
- 1 x Instruction Manual
- 1 x Robust Carry Case with Protective Foam Inserts
- Kit Part No: 646464-01



WEIGHTS AND DIMENSIONS

TOOL WEIGHT = 21.5 kg (47.4 lbs)
GROSS KIT WEIGHT = 38.5 kg (84.9 lbs)

Carry Case Dimensions: 820 x 520 x 160 mm (32.31" x 20.49" x 6.29")

TOOL DIMENSIONS - OPEN

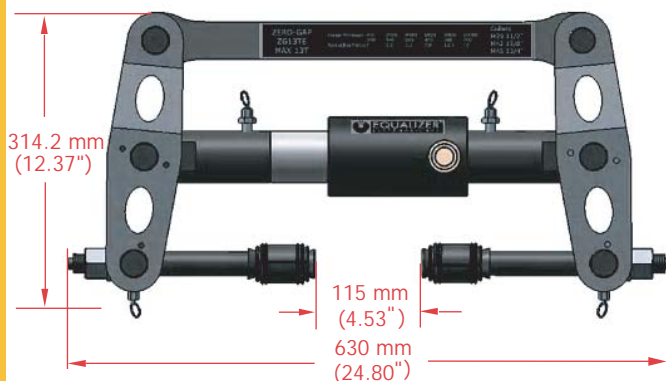

TOOL DIMENSIONS - CLOSED

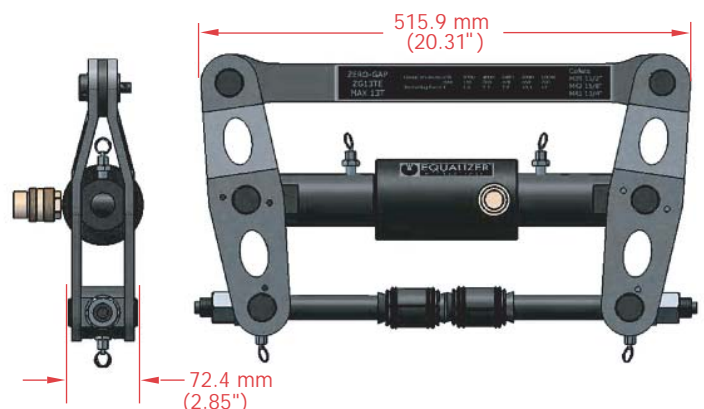

RANGE OF APPLICATION

The ZG13TE is useable on all standard flanges that have been specified to accept the following bolt sizes: M39, M42, M45, 1 1/2", 1 5/8", 1 3/4". This includes ANSI, DIN, SPO, ASME, API, and BS flanges.

For a detailed range of application please request the Zero-Gap Operator Instruction Manual.

COLLET HEAD PARTS LIST AND EXPLODED DRAWING

ITEM	DESCRIPTION	PART NO.	QUANTITY
01	COLLET HOLDER	640401-02	02
02	M39 SPRING RING	642201-04	04
	M42 SPRING RING	642401-04	04
	M45 SPRING RING	642601-04	04
03	M39 COLLET	640101-02	02
	M42 COLLET	640201-02	02
	M45 COLLET	640301-02	02
04	DRIVE CONE	640501-02	02
05	DRIVE TUBE	641601-02	02
06	COLLET UNION	640601-02	02
07	CENTERING SPRING 1	402201-02	02
08	COLLET NUT	640901-02	02
09	M12 SPRING PLUNGER	641001-02	02

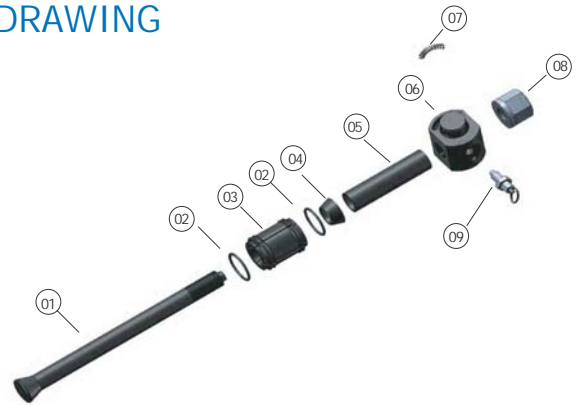

ZG13TE PARTS LIST AND EXPLODED DRAWING

ITEM	DESCRIPTION	PART NO.	QUANTITY
01	LEG RETAINING RING	641301-10	10
02	LEG	641101-04	04
03	M10 SPRING PLUNGER	900502-02	02
04	CANTILEVER	641501-01	01
05	ACTUATOR UNION	641901-02	02
06	ACTUATOR PIN	641401-02	02
07	PULL PIN	641701-01	01
08	SEE COLLET HEAD PART LIST		
09	CANTILEVER PIN	643201-01	01
10	ACTUATOR ASSEMBLY	644001-01	01

