



# SW9™

## MECHANICAL FLANGE SPREADER

### SPREADING FORCE:

150 ft/lbs (203 N/m) = 9 T (90 kN)

It is recommended that tools are used in pairs giving  
2 x 9 = 18 T (180 kN)

TOOL WEIGHT = 5.5 kg (12.13 lb)

### KIT COMPONENTS

- 1 x SW9™ Wedgehead
- 1 x 150 ft/lbs (203 N/m) Torque Wrench with 22 mm Socket
- 1 x Safety Block
- 1 x Instruction Manual
- 1 x Cardboard Packaging
- Kit Part No: 323232-01



### WEIGHTS AND DIMENSIONS

- Tool Weight = 5.5 kg (12.13 lb)
- Torque Wrench = TO FOLLOW
- Safety Block = 0.5 kg (1.10 lb)
- GROSS WEIGHT = TO FOLLOW

Packaging Dimensions: 190 x 180 x 320 mm (7.48" x 7.09" x 12.60")

#### TOOL DIMENSIONS - CLOSED

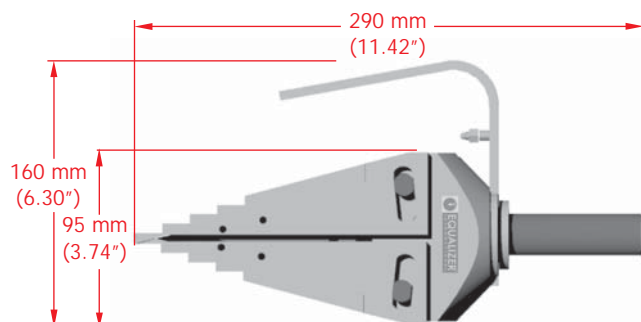

#### TOOL DIMENSIONS - OPEN

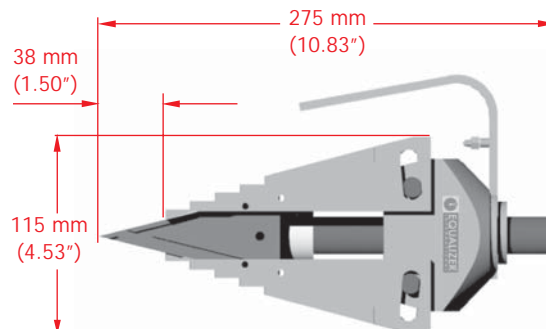

### TOOL DIMENSIONS - CLOSED

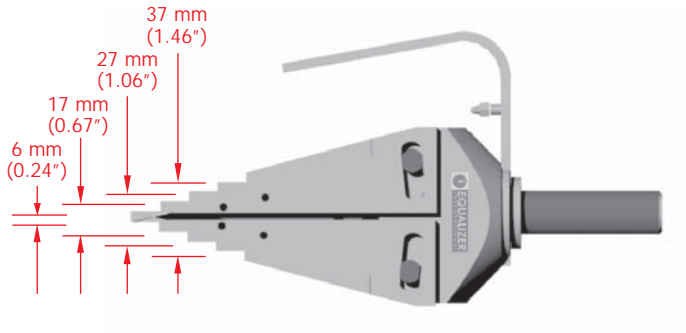

### TOOL DIMENSIONS - OPEN

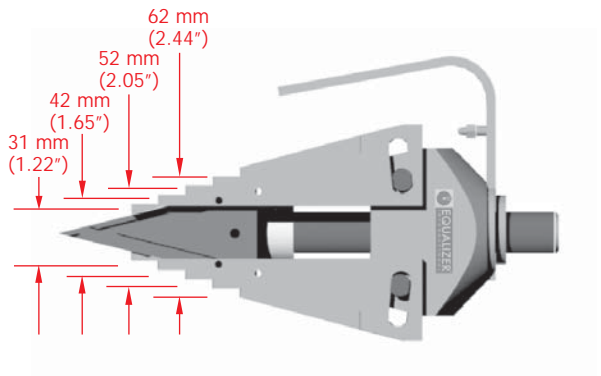

### SAFETY BLOCK

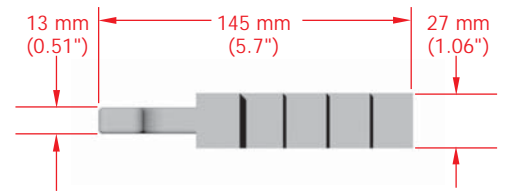
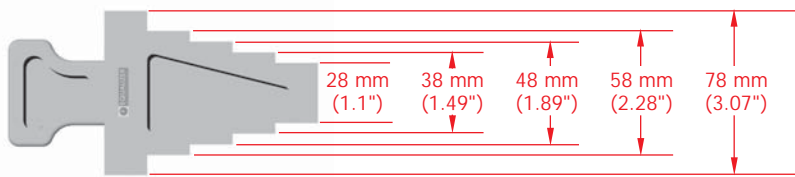

### RANGE OF APPLICATION

All flanges with a minimum access gap of 6 mm (0.24")

### PARTS LIST AND EXPLODED DRAWING

ITEM	PART No.	DESCRIPTION	QUANTITY
01	300101-01	WEDGE	01 each
02*	301502-01	NUT	01 each
03*	301601-01	THRUST BEARING SET	01 set
04	301802-01	BEARING HOUSING	01 each
05	310601-01	GREASE NIPPLE	01 each
06	301201-08	ROLL PINS	01 set of 8
07	300203-02	JAWS	01 set of 2
08	312301-01	HANDLE SLEEVE	01 each
09	302202-01	PUSH-ROD	01 each
10	302101-01	CIRCLIP FOR HANDLE	01 each
11	302001-01	HANDLE	01 each
12	301901-01	MALE / FEMALE ADAPTOR	01 each
13*	300501-04	SLIDE PINS	01 set of 4
14	301102-01	BODY	01 each
15*	300401-04	M5 X 6 GRUB SCREWS	01 set of 4
16*	301301-01	M6 X 10 GRUB SCREW	01 each
17	TO FOLLOW	TORQUE WRENCH	01 each

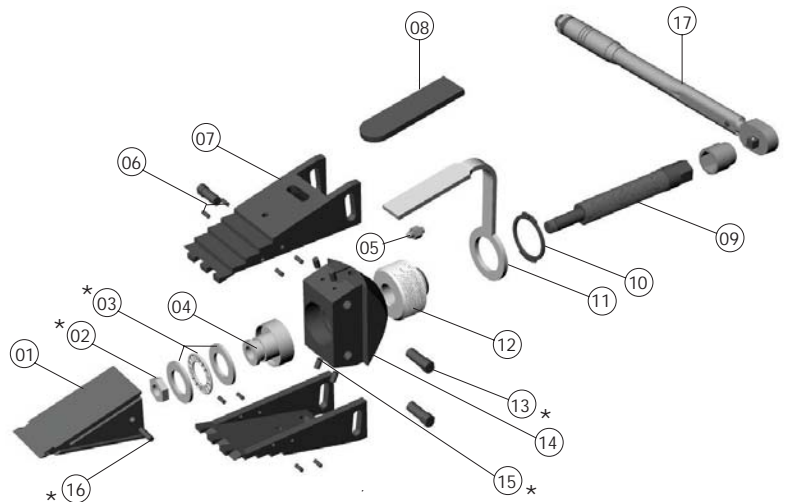

\*Items 02, 03, 13, 15 & 16 are supplied in Repair Kit Part No: 310501-01

### STEPPED BLOCK KIT (AVAILABLE AS AN OPTION)

#### KIT COMPONENTS

- 2 x Stepped Blocks
- 2 x M6 x 10 mm Countersunk Screws
- 1 x 4mm Hex Key
- Kit Part No: 303301-01

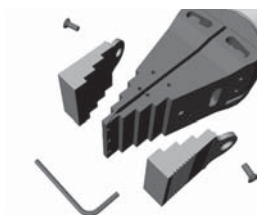

#### WEIGHTS AND DIMENSIONS

- Stepped Block = 0.52 kg (1.14 lb)
- GROSS WEIGHT = 1.5 kg (3.5 lb)

