



SW15TE

HYDRAULIC FLANGE SPREADER MAXI KIT

SPREADING FORCE = 15.5 T (155 kN)

It is recommended that tools are used in pairs giving
2 x 15.5 = 31 T (310 kN)

TOOL WEIGHT = 7 kg (15.4 lbs)

KIT COMPONENTS

- 2 x SW15TE Wedgeheads
- 2 x 10,000 psi (700 bar) Hydraulic Hoses, 2 m (78.75") each
- 2 x 10,000 psi (700 bar) Hydraulic Cylinders
- 1 x 10,000 psi (700 bar) HP350D Sealed Hand Pump with Gauges
- 2 x Safety Blocks
- 1 x Instruction Manual
- 1 x Robust Carry Case with Protective Foam Inserts
- Kit Part No: 353535-01



WEIGHTS AND DIMENSIONS

Tool with Hydraulic Cylinder	= 7 kg (15.4 lb)
Safety Block	= 0.5 kg (1.1 lb)
Hand Pump	= 4.5 kg (9.9 lb)
Hydraulic Hose	= 1.0 kg (2.2 lb)
Carry Case with Foam Inserts	= 5 kg (11.02 lb)
GROSS WEIGHT	= 29 kg (63.9 lb)

Carry Case Dimensions: 550 x 390 x 180 mm (21.65" x 15.35" x 7.09")

TOOL DIMENSIONS - CLOSED

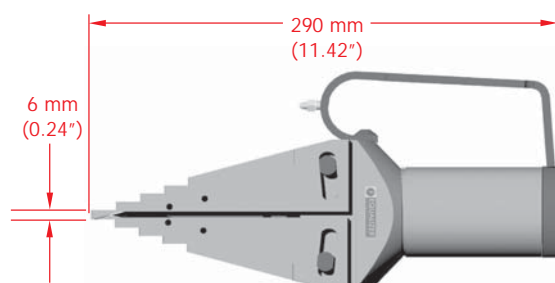

TOOL DIMENSIONS - OPEN

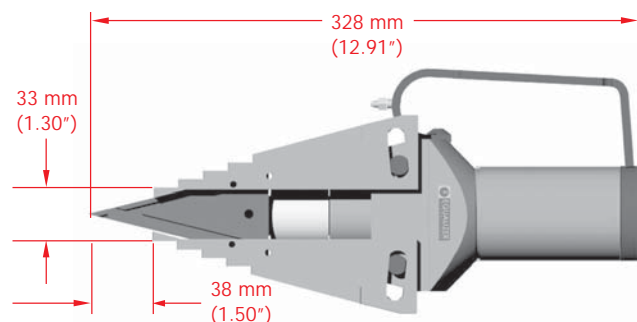

TOOL DIMENSIONS - CLOSED

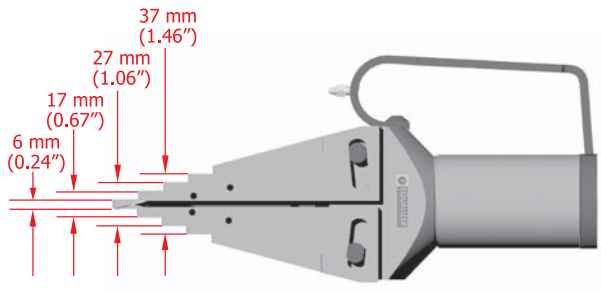

TOOL DIMENSIONS - OPEN

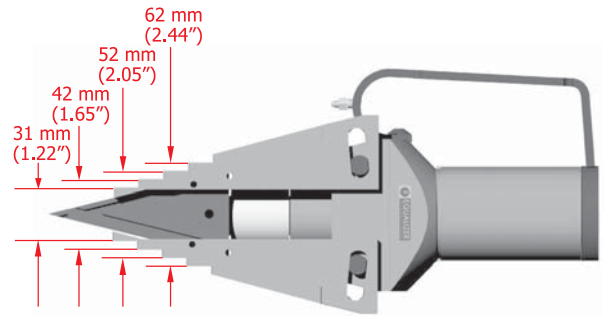

SAFETY BLOCK DIMENSIONS

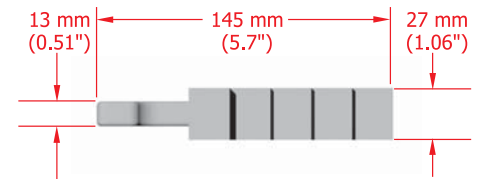
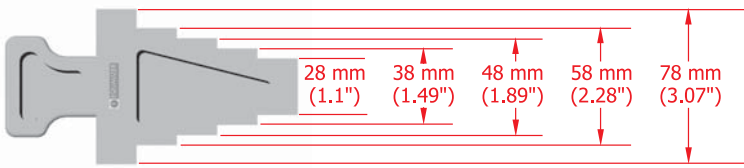

RANGE OF APPLICATION

All flanges with a minimum access gap of 6 mm (0.24")

PARTS LIST AND EXPLODED DRAWING

ITEM	PART No.	DESCRIPTION	QUANTITY
01	300701-01	HANDLE	01 each
02	401801-01	RETAINING SCREW FOR HANDLE	01 each
03	300203-02	JAWS	01 set of 2
04	301201-08	ROLL PINS	01 set of 8
05	300501-04	SLIDE PINS	01 set of 4
06	300301-01	CONNECTOR / PUSH ROD	01 each
07	300101-01	WEDGE	01 each
08	301301-01	GRUB SCREW	01 each
09	300401-04	GRUB SCREW	01 set of 4
10	301102-01	BODY	01 each
11	301002-01	HYDRAULIC CYLINDER	01 each
12	310601-01	GREASE NIPPLE	01 each
13	300801-02	BASE SCREWS FOR HANDLE	01 set of 2
14	301402-01	CYLINDER REPAIR KIT (Not Illustrated)	01 kit

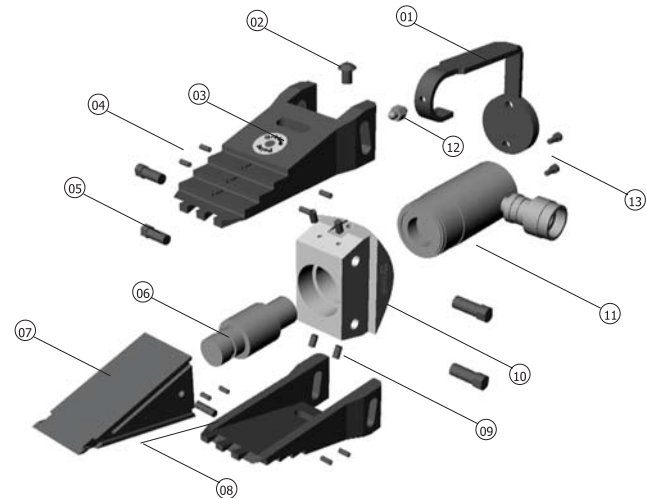

STEPPED BLOCK KIT (AVAILABLE AS AN OPTION)

KIT COMPONENTS

- 2 x Stepped Blocks
- 2 x M6 x 10 mm Countersunk Screws
- 1 x 4 mm Hex Key
- Kit Part No: 303301-01

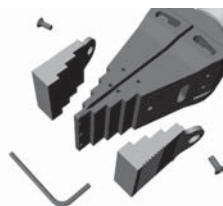

WEIGHTS AND DIMENSIONS

Stepped Block = 0.52 kg (1.14 lb)
GROSS WEIGHT = 1.5 kg (3.5 lb)

