



HT125KM

HAND ALIGNMENT TOOL

ALIGNING FORCE:

Mechanical Advantage 5 to 1

25 kg (55 lbs) at handle = 125 kg (276 lbs) at flange

TOOL WEIGHT = 2 kg (4.4 lbs)

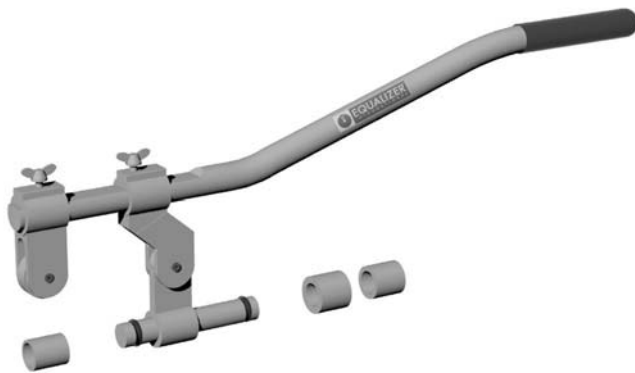

COMPONENT PARTS

- 1 x HT125KM Tool
- 3 x Adaptor Bushes
- 1 x Instruction Manual
- Product Code: HT125KG

MINIMUM EXTENSION

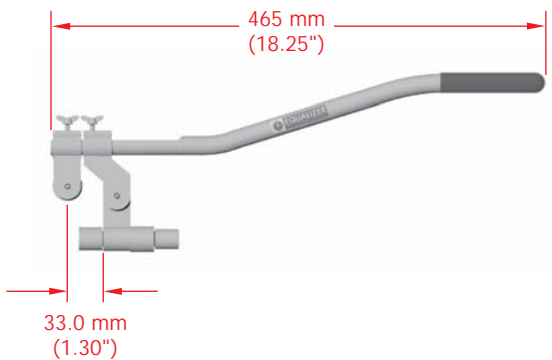

MAXIMUM EXTENSION

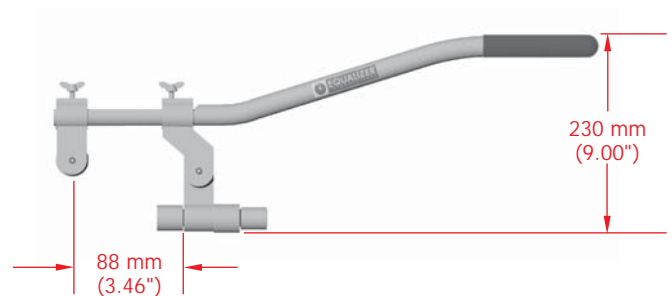

RANGE OF APPLICATION

TABLE A: RANGE OF APPLICATION on ANSI, BS & API FLANGES

pressure (psi)	FLANGE SIZE (inches)																
	1/2	3/4	1	1 1/4	1 1/2	2	2 1/2	3	3 1/2	4	5	6	8	10	12	14	16
150						+	+	+	+	+	●	●	●	■	■	◆	◆
300		+	+	+	+	+	●	●	●	●	●	●	■				
400		+	+	+	●	+	●	●	■	■							
600		+	+	+	●	+	◆	●	■	■							
900	●	●	■	■	◆	■	◆	■									
1500	●	●	■	■	◆	■											
2500	●	●	■														

+ Pin Only = Ø 17.0 mm (.669")
 ● Bush A = Ø 21.3 mm (.836")
 ■ Bush B = Ø 24.4 mm (.957")
 ◆ Bush C = Ø 27.4 mm (1.07")

TABLE B: RANGE OF APPLICATION on DIN FLANGES

DN PN	FLANGE SIZE (mm)													
	25	32	40	50	65	80	100	125	150	200	250	300	350	400
6						+	+	+	+	+	+	●	●	●
10		+	+	+	+	+	+	+	●	●	●	●	●	■
16		+	+	+	+	+	+	+	●	●	■	■	■	◆
25		+	+	+	+	+	+	+	●	■	◆	◆		
40		+	+	+	+	+	+	+	●	●				
64	+		●	●	●	●	■	◆						
100	+		●	■	■	■	◆							
160	+		●	■	■									

+ Pin Only = Ø 17.0 mm (.669")
 ● Bush A = Ø 21.3 mm (.836")
 ■ Bush B = Ø 24.4 mm (.957")
 ◆ Bush C = Ø 27.4 mm (1.07")

ITEM	PART No.	DESCRIPTION	QUANTITY
01	201201-01	HANDLE SLEEVE-BLUE	01 each
02	200102-01	MAIN BAR	01 each
03*	200901-02	BUTTERFLY NUT	01 set of 2
04	200202-01	LIFTING ASSEMBLY	01 each
05	200302-01	COUNTER-BALANCE	01 each
06*	201102-01	ROLL PIN 3/4"	01 each
07	200502-01	ROLLER	01 each
08	200601-01	BUSH A	01 each
09	200402-01	BOLT-HOLE LEVER	01 each
10*	201001-02	"O" RING	01 set of 2
11	200801-01	BUSH C	01 each
12	200701-01	BUSH B	01 each
13*	201401-01	ROLL PIN 1/2"	01 each

PARTS LIST AND EXPLODED DRAWING

*Repair Kit Part No: 201301-01 with Items 03, 06, 10 & 13

