



# HP350S

## HYDRAULIC SINGLE PORT SEALED HAND PUMP

### PRESSURE RATING:

1ST STAGE: 13.8 bar (197 psi)

2ND STAGE: 700 bar (10,000 psi)

CAPACITY: 350 cc

TOOL WEIGHT = 4 kg (8.82 lbs)

### KIT COMPONENTS

- 1 x HP350S Pump Unit
  - 1 x 0-1000 bar (0-15,000 psi) Gauge
  - 1 x 3/8" Port Gauge Adaptor
  - 1 x Instruction Manual
  - 1 x Cardboard Packaging
- Product Code: HP350SMIN



### TOOL DESCRIPTION

The HP350S hydraulic hand pump unit is tailored for use with Equalizer International hydraulic equipment. Its output is regulated to 700 bar (10,000 psi) and is delivered from an output port threaded 3/8" NPT. The pump can be used with any 700 bar (10,000 psi) rated hydraulic equipment with an oil capacity of 350 cc (21.35 in<sup>3</sup>) or less.

The diaphragm oil reservoir means that, unlike conventional hand pump units, the HP350S is operable at all angles and is highly resistant to accidental spillage of hydraulic fluid.

For further details please request an instruction manual.

MODEL		HP350S
PUMP TYPE		TWO SPEED
PRESSURE RATING (bar/psi)	1ST STAGE 2ND STAGE	13.8 (197) 700 (10,000)
USABLE OIL CAPACITY (cc/in <sup>3</sup> )		350.0 (21.35)
OIL VOLUME PER STROKE (cc/in <sup>3</sup> )	1ST STAGE 2ND STAGE	13.0 (0.79) 2.8 (0.17)
MAX HANDLE EFFORT (kg/lb)		25 (55.12)
PISTON STROKE (mm/in)		18.0 (0.71)

### WEIGHTS AND DIMENSIONS

Tool Only = 4 kg (8.82 lbs)

GROSS KIT WEIGHT = 4.5 kg (9.92 lbs)

Packaging Dimensions:

180 x 180 x 600 mm (7.09" x 7.09" x 23.62")

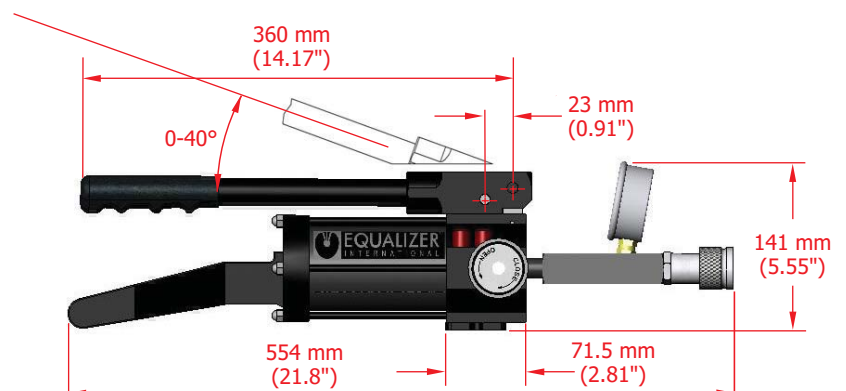
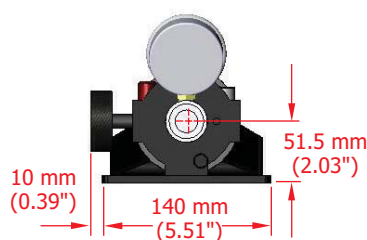

## RANGE OF APPLICATION

All hydraulic equipment with an oil capacity of 350 cc (23.13 in<sup>3</sup>) or less and an operating pressure of 10,000 psi (700 bar)

## PARTS LIST AND EXPLODED DRAWING

ITEM	PART No.	DESCRIPTION	QUANTITY
01	710101-01	PUMP HOUSING	01
02	715100-01	SERVICE KIT A:	
03		- OIL FILTER	01
04		- O-RING	01
05		- RESERVOIR BLADDER	01
06	710601-01	RESERVOIR	01
07	715200-01	SERVICE KIT B:	
08		- TAIL BASE	01
09		- SCREW	04
		- NUT	04
10	715300-01	SERVICE KIT C:	
11		- O-RING	01
12		- BACK-UP RING	01
13		- PUMP PISTON	01
14		- SNAP RING	01
15		- O-RING	01
16		- BACK-UP RING	01
		- PUMP PISTON	01
17	715400-01	SERVICE KIT D:	
18		- PISTON PIN	01
19		- YOKE PIN	01
20		- RETAINING RING	01
21		- YOKE	01
		- HANDLE	01
22	715500-01	SERVICE KIT E:	
23		- YOKE BASE	01
24		- PIN	01
25		- SCREW	02
		- OIL SEAL	01
26	715600-01	SERVICE KIT F:	
27		- WASHER	01
28		- COUPLERS	01
29		- CHECK BALL	04
30		- SCREW	01
31		- RELEASE VALVE	01
32		- PIN	01
33		- SCREW	03
		- SCREW	01
34	715700-01	SERVICE KIT G:	
35		- CHECK BALL	02
36		- SPRING	02
37		- CHECK BALL	02
38		- SPRING	02
39		- WASHER	02
		- SCREW	02

ITEM	PART No.	DESCRIPTION	QUANTITY
40	715800-01	SERVICE KIT H:	
41		- CHECK BALL	02
42		- SPRING END CAP	02
43		- SPRING	01
44		- SPRING	01
45		- O-RING	02
46		- SCREW	02
47		- CAP	02
48	714701-01	O-RING	01
	714802-01	SCREW	01
49	715900-01	SERVICE KIT I:	
50		- BASE PLATE	01
		- SCREW	02

