



FA3TM

MECHANICAL FIXED FLANGE AND ROTATIONAL ALIGNMENT TOOL

ALIGNING FORCE:
50 ft/lbs (68 N/m) = 3.3 T (33 kN)

TOOL WEIGHT = 8.1 kg (17.82 lbs)

KIT COMPONENTS

- 1 x FA3TM Tool
 - 1 x 50 ft/lbs (67.8 Nm) Torque Wrench with 22 mm Socket
 - 1 x Instruction Manual
 - 1 x Carry-Case with Protective Foam Inserts
- Product Code: FA3TMSTD



WEIGHTS AND DIMENSIONS

- Tool Only = 8.1 kg (17.82 lbs)
- Carry-Case with Foam Inserts = 6 kg (13.23 lbs)
- GROSS KIT WEIGHT = 14 kg (30.90 lbs)**

Carry-Case Dimensions:
520 x 375 x 165 mm (20.47" x 14.76" x 6.50")

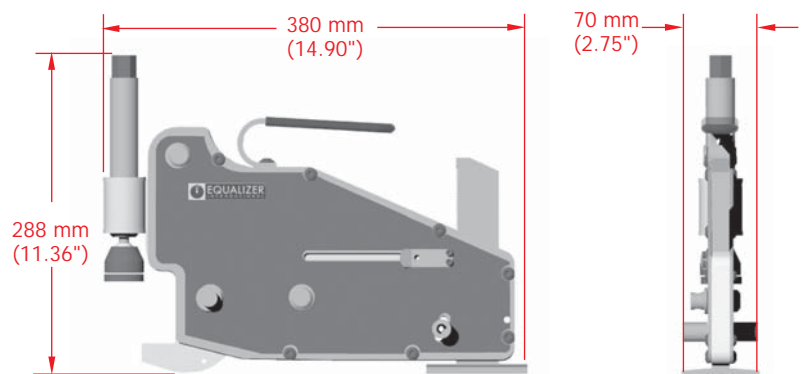

MINIMUM EXTENSION

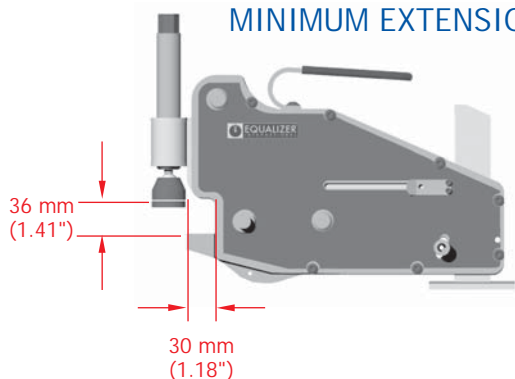

MAXIMUM EXTENSION

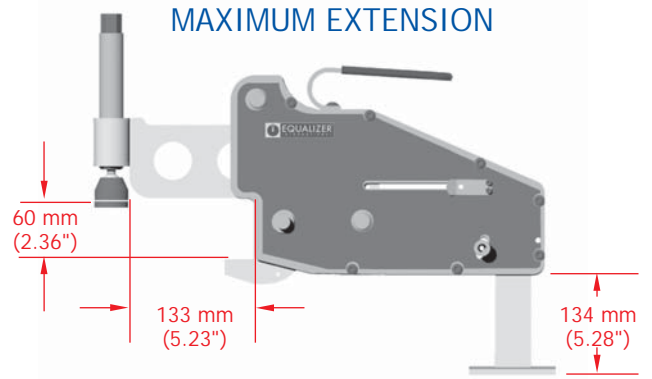

RANGE OF APPLICATION

BY FLANGE TYPE, CLASS AND DIAMETER

ANSI B 16.5			API		BS 3293	
LAP JOINT FLANGES 150# NIL 300# 12" THRU 24" 400# 10" THRU 24" 600# 8" THRU 24" 900# 5" THRU 24" 1500# 4" THRU 16" 2500# 2" THRU 10"	THREADED FLANGES 150# 8" THRU 24" 300# 8" THRU 24" 400# 3 1/2" THRU 24" 600# 3 1/2" THRU 24" 900# 1" THRU 20" 1500# 1" THRU 10" 2500# 1" THRU 6"	WELD NECK FLANGES 150# 10" THRU 24" 300# 8" THRU 24" 400# 3" THRU 24" 600# 3 1/2" THRU 24" 900# 1" THRU 20" 1500# 1" THRU 10" 2500# 1" THRU 6"	API STANDARD 605WELD NECK FLANGES 150# 34" THRU 60" 300# 26" THRU 36"	API TYPE 6BXWELD NECK FLANGES 10,000#2 9/16" THRU 5 1/8" 15,000#1 13/16" THRU 4 1/16" 20,000#1 13/16" THRU 3 1/16"	SLIP-ON FLANGES 150# 26" THRU 48" 300# 26" THRU 36" 400# 26" THRU 32" 600# 26" ONLY	WELD NECK FLANGES 150# 26" THRU 48" 300# 26" THRU 36" 400# 26" THRU 32" 600# 26" ONLY
SLIP-ON FLANGES 150# 10" THRU 24" 300# 8" THRU 24" 400# 3" THRU 24"	600# 3 1/2" THRU 24" 900# 1" THRU 20" 1500# 1" THRU 2 1/2"	SOCKET WELD FLANGES 1500# 1" THRU 2 1/2"	API TYPE 6BINTEGRAL FLANGES 10,000#2 9/16" THRU 21 1/4" 15,000#1 13/16" THRU 13 5/8" 20,000#1 13/16" THRU 9"	API TYPE 6BXINTEGRAL FLANGES 2000# 3 1/2" THRU 21 1/4" 3000# 2 1/16" THRU 16 3/4" 5000# 2" THRU 9"	SLIP-ONFLANGES RTJ 300# 26" THRU 36" 400# 26" ONLY	WELD NECKFLANGES RTJ 300# 26" THRU 28" 400# 26" ONLY

PARTS LIST AND EXPLODED DRAWING

ITEM	PART No.	DESCRIPTION	QUANTITY	ITEM	PART No.	DESCRIPTION	QUANTITY
01	400203-01	50ft/lbs TORQUE WRENCH	01 each	21	400501-01	SWIVEL	01 each
02	400204-01	22 mm SOCKET	01 each	22	400601-01	THRUST BEARING SET	01 each
03	400301-01	SCREW BOLT	01 each	23	400801-01	FRICTION PAD	01 each
04	401001-01	WING C/W BOSS	01 each	24	400901-01	RETAINING SCREW	01 each
05	401401-02	INNER ROLLER	01 set of 2	25	402601-02	COUNTER-SUNK SCREWS	01 set of 2
06	401501-02	NEEDLE BEARING	01 set of 2	26	402501-01	DROP LEG PAD	01 each
07	401601-02	OUTER ROLLER	01 set of 2	27	402401-01	DROP LEG	01 each
08	401101-01	BODY PLATES & FRAME	01 set	28	402301-01	GRUB SCREW	01 each
09	401301-02	SPIRAL CLIP	01 set of 2	29	402201-01	SPRING	01 each
10	402001-01	WING RETAINING CLIP	01 each	30	402901-01	DROP LEG LOCK	01 each
11	402002-02	M3 SCREW	01 set of 2	31	402902-01	ADJUSTING SCREW	01 each
12	402701-02	M5 x 20MM SCREW	01 set of 2	32	401201-02	ROLLER PIN	01 set of 2
13	402801-02	RELEASE KNOB	01 set of 2	33	308201-01	HANDLE	01 each
14	401901-14	SCREWS FOR SIDE PLATES	01 set of 14	34	401702-01	HANDLE SLEEVE-YELLOW	01 each
15	403102-01	PULL RING	01 each	35	401801-01	RETAINING SCREW	01 each
16	403101-01	PULL PIN	01 each	36	402101-01	SCREW (DROP LEG)	01 each
17	403201-01	ROLL PIN	01 each	37	404501-02	PLASTIC WING INSERTS	01 set of 2
18	403301-01	BALL SPRING PLUNGER	01 each	38	404601-01	WIRE	0.2 m
19	403001-01	LIFT HOOK	01 each	39	403401-01	DECALS SET (not illustrated)	01 kit
20	400401-01	SPRING CLIP	01 each	40	403501-01	CARRY-CASE WITH FOAM INSERT (not illustrated)	01 kit

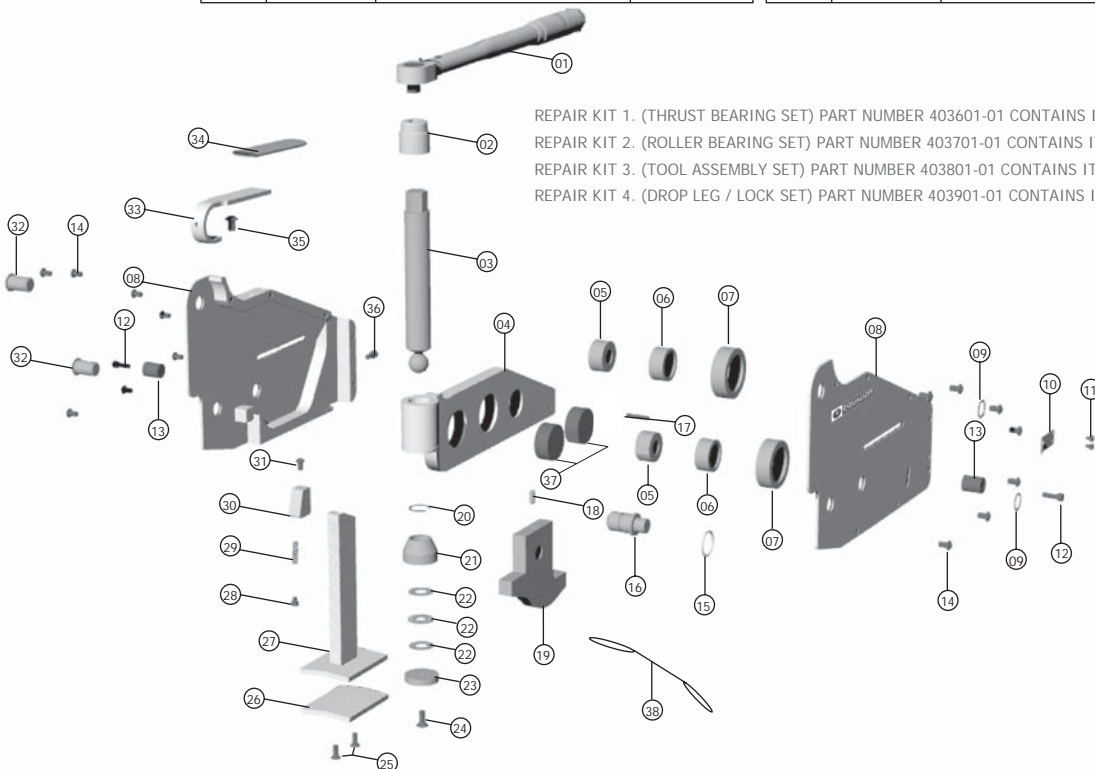

REPAIR KIT 1. (THRUST BEARING SET) PART NUMBER 403601-01 CONTAINS ITEMS 20,22 & 24.

REPAIR KIT 2. (ROLLER BEARING SET) PART NUMBER 403701-01 CONTAINS ITEMS 5,6,7 & 9.

REPAIR KIT 3. (TOOL ASSEMBLY SET) PART NUMBER 403801-01 CONTAINS ITEMS 10, 11, 14 & 36.

REPAIR KIT 4. (DROP LEG / LOCK SET) PART NUMBER 403901-01 CONTAINS ITEMS 12,13,25,26,28,29,30 & 31.