

"innovation in its most functional form"

PRODUCT DATA SHEET



HP550S

HYDRAULIC SINGLE PORT SEALED HAND PUMP

PRESSURE RATING:

1st STAGE: 13.8 bar (197 psi)

2nd STAGE: 700 bar (10,000 psi)

CAPACITY: 550cc

TOOL WEIGHT = 5kg (11.02lbs)

KIT COMPONENTS

- 1 x HP550S Pump Unit
- 1 x 0-1000 bar (0-15,000 psi) Gauge
- 1 x 3/8" Port Gauge Adaptor
- 1 x Instruction Manual
- 1 x Cardboard Packaging
- Product Code: HP550SMIN



MODEL	HP550S	
PUMP TYPE	TWO SPEED	
PRESSURE RATING (bar/psi)	1ST STAGE	13.8 (197)
	2ND STAGE	700 (10,000)
USABLE OIL CAPACITY (cc/in ³)	550.0 (30.51)	
OIL VOLUME PER STROKE (cc/in ³)	1ST STAGE	13.0 (0.79)
	2ND STAGE	2.8 (0.17)
MAX HANDLE EFFORT (kg/lb)	25 (55.12)	
PISTON STROKE (mm/in)	18.0 (0.71)	

TOOL DESCRIPTION

The HP550S hydraulic hand pump unit is tailored for use with Equalizer International hydraulic equipment. It's output is regulated to 700 bar (10,000 psi) and is delivered from an output port threaded 3/8" NPT. The pump can be used with any 700 bar (10,000 psi) rated hydraulic equipment with an oil capacity of 550cc (30.51 in³) or less. The diaphragm oil reservoir means that, unlike conventional hand pump units, the HP550S is operable at all angles and is highly resistant to accidental spillage of hydraulic fluid. For further details please request an instruction manual.

WEIGHTS AND DIMENSIONS

- Tool Only = 5 kg (11.02 lbs)
- GROSS KIT WEIGHT = 5.5 kg (12.13 lbs)

Packaging Dimensions:

180 x 180 x 700 mm (7.09" x 7.09" x 27.56")

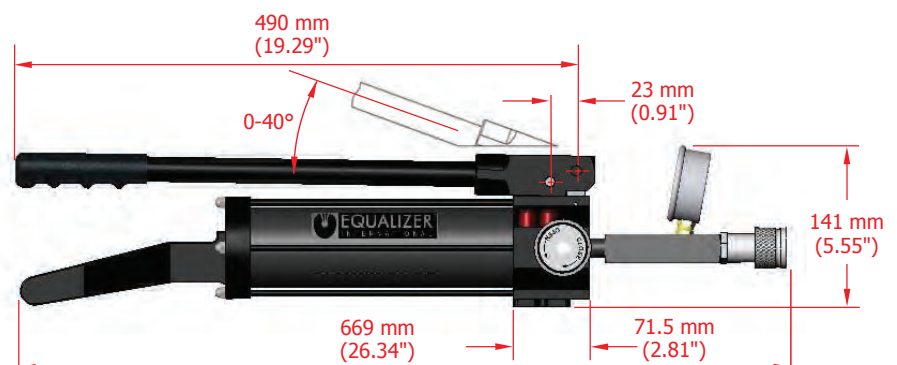
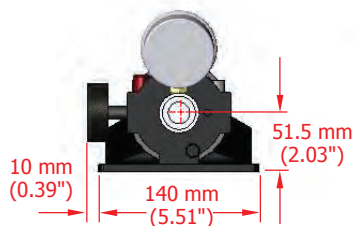

HP550S

HYDRAULIC SINGLE PORT

SEALED HAND PUMP



"innovation in its most functional form "

RANGE OF APPLICATION

All Hydraulic equipment with an oil capacity of 550cc (30.51 in³) or less and an operating pressure of 10,000 psi (700 bar)

PARTS LIST AND EXPLODED DRAWING

ITEM	PART No.	DESCRIPTION	KIT QUANTITY	PUMP QUANTITY
01	710101-01	PUMP HOUSING		01
02	730601-01	RESERVOIR		01
	715300-01	SERVICE KIT C:		
03		- O-RING	01	01
04		- BACK-UP RING	01	01
05		- H.P. PISTON	01	01
06		- SNAP RING	01	01
07		- O-RING	01	01
08		- BACK-UP RING	01	01
09		- L.P. PISTON	01	01
	715500-01	SERVICE KIT E:		
10		- YOKE BASE	01	01
11		- SPRING PIN	01	01
	715600-01	SERVICE KIT F:		
12		- SEAL	01	01
13		- WASHER	01	01
14		- RELEASE VALVE SCREW	01	01
15		- SCREW	01	01
16		- RELEASE KNOB	01	01
17		- COUPLERS	01	01
37		- CHECK BALL	01	01
	715700-01	SERVICE KIT G:		
18		- SPRING	02	02
19		- STEEL BALL	02	02
20		- OUTLET BALL SPRING	02	02
21		- COPPER WASHER	02	02
22		- VALVE COVER SCREW	02	02
23		- STEEL BALL	02	02
	715800-01	SERVICE KIT H:		
24		- STEEL BALL	01	01
25		- SPRING END CAP	01	01
26		- L.P. SPRING	01	01
27		- O-RING	02	02
28		- OVERLOAD COVER SCREW	01	01
29		- CAP	02	02
30		- CONE SEAT	01	01
31		- CONE	01	01
32		- LONG SEPARATOR SPRING	01	01
33		- OVERLOAD COVER SCREW	01	01
	715900-01	SERVICE KIT I:		
34		- BASE PLATE	01	01
35		- SCREW	02	02
	716100-01	SERVICE KIT K:		
36		- SCREW	04	03
37		- CHECK BALL	04	03
38		- SCREW	01	01
54		- SCREW	01	01
	716200-01	SERVICE KIT L:		
39		- GAUGE COUPLER MALE	01	01
40		- GAUGE	01	01

ITEM	PART No.	DESCRIPTION	KIT QUANTITY	PUMP QUANTITY
	716300-01	SERVICE KIT M:		
41		- GAUGE COUPLER FEMALE	01	01
42		- COUPLER	01	01
43		- PORT GAUGE ADAPTOR	01	01
	735100-01	SERVICE KIT N:		
44		- RESERVOIR BLADDER	01	01
45		- OIL FILTER	01	01
46		- O-RING	01	01
47		- REFILLING PLUG	01	01
	735300-01	SERVICE KIT O:		
48		- HANDLE	01	01
49		- YOKE	01	01
50		- PISTON PIN	01	01
51		- YOKE PIN	01	01
52		- RETAINING RING	01	01
53		- HANDLE GRIP	01	01
54		- SCREW	01	01
	735200-01	SERVICE KIT P:		
55		- SCREW	04	04
56		- TAIL BASE	01	01
57		- SPRING WASHER	04	04
58		- NUT	04	04

